



**DEPENDABLE EMERGENCY COMMUNICATIONS**  
Electronic Micro Systems Inc.  
125 Ricefield Lane • Hauppauge NY 11788  
631-864-3699 • 800-527-9156 • Fax 631-864-2631  
[www.ElectronicMicroSystems.com](http://www.ElectronicMicroSystems.com)

—A—  
**HALMA**  
**GROUP**  
COMPANY

# A781

LINE SHARING SWITCH  
LSS

INSTALLATION AND OPERATION

## 1. GENERAL

The A781 is designed as a Line Sharing Switch (LSS) to allow up to 8 telephones to share one telephone line. The LSS consists of a box with eight RJ-11 connectors for telephones, one RJ-11 for the incoming telephone line and an AC power adapter.

When a telephone goes off hook the LSS connects it to the incoming line. If the line is in use, any other telephone trying to seize the line will receive busy signal.

The incoming line can be used to call in and test the connected telephones.

An LED indicates LSS status. When power is present the LED will flash at a rate of 5 times per second with the incoming line idle and once per second if the line is in use.

## 2. INSTALLATION

### 2.1 Mechanical

The A781 LSS is wall mounted using the four holes on the flanges. See SD0006-2 The LSS should be located such that there is access to the sides and the bottom.

### 2.2 Electrical

Power for the A781 LSS comes from an external AC power adapter. This adapter must be plugged into a local 120VAC outlet, which is always on..

Modular telephone cords are used to connect the local telephones or wiring to the RJ-11's located on the left side of the LSS. These RJ-11's are labeled from the top down as 10 to 17. The incoming telephone line is connected, using a modular cord, to the RJ-11 on the right side.

### 2.3 Telephone wiring

If the telephones are located away from the LSS, use the wiring in the drawing below to extend the range.

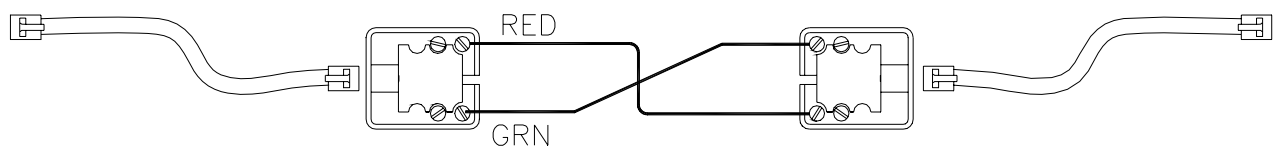

### 3. PROGRAMMING

#### 3.1 Programming the LSS

There is no programming necessary.

### 4. OPERATION

#### 4.1 Outgoing Calls

When the incoming line is not in use, any telephone connected to the LSS can go off hook and use the line to place a call. During the call the LED will change to a flash rate of once per second. When the telephone goes on hook, the line is released and the LED returns to an idle flash rate of 5 times per second.

If the incoming line is in use, any other telephone going off hook will receive a busy tone.

#### 4.2 Incoming Calls

The LSS can receive incoming calls for testing the telephones. When the LSS answers an incoming call, a code is dialed to access any of the telephones. Once a connection is established to a telephone, the normal test procedure for that model is used.

The codes are as follows:

- Station 10 is 910#
- Station 11 is 911#
- Station 12 is 912#
- Station 13 is 913#
- Station 14 is 914#
- Station 15 is 915#
- Station 16 is 916#
- Station 17 is 917#

When testing is complete, the line is released and becomes available for use.

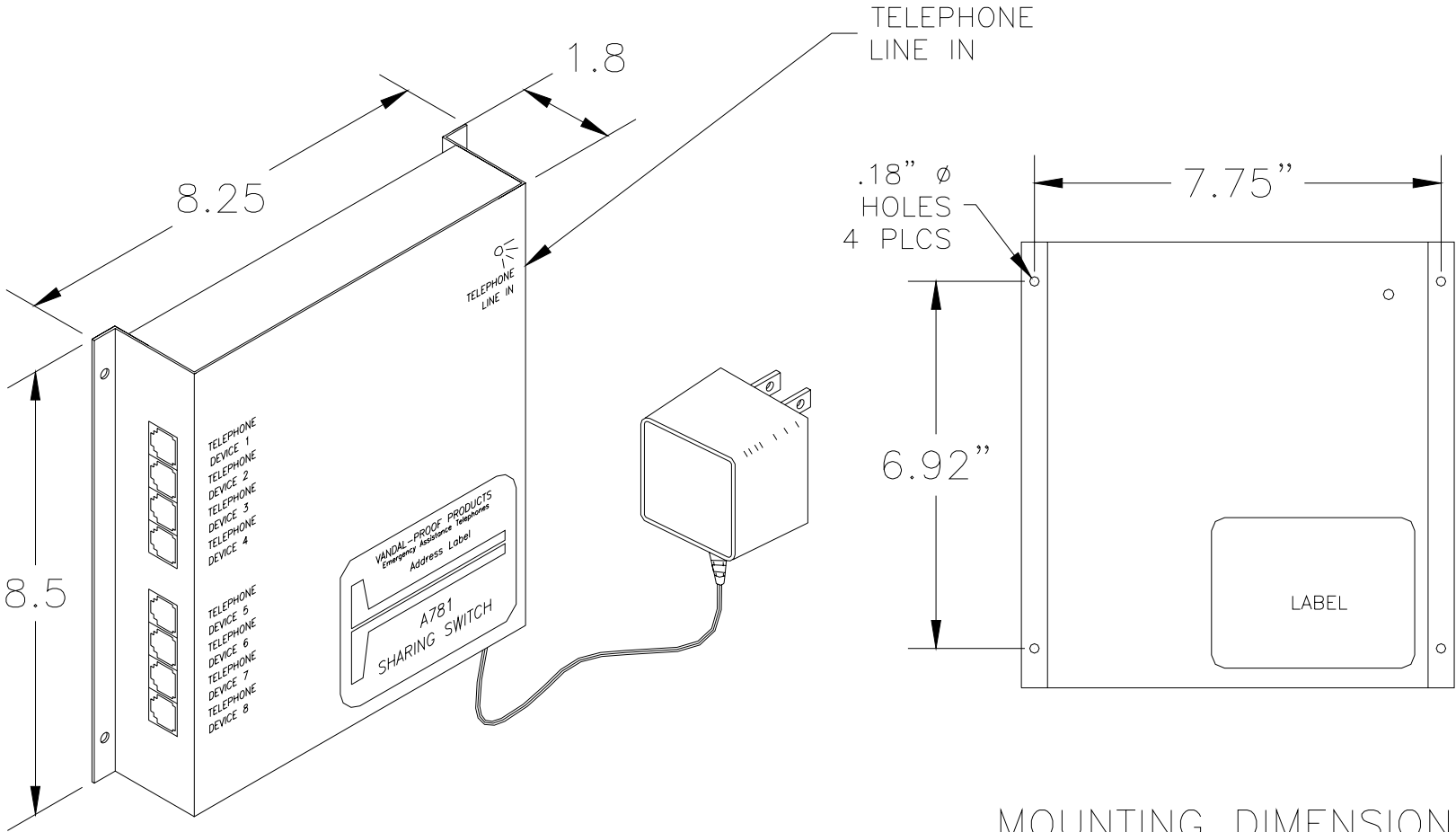

OVERALL DIMENSIONS

MOUNTING DIMENSIONS

# A781 MOUNTING DIMENSIONS

## SD0006-2

**VPP** Electronic Micro Systems  
 125 RICEFIELD LANE  
 HAUPPAUGE, N.Y., 11788  
 (631)864-4742 FAX (631)864-4770