

T21 10

Emergency/Assistance Telephone

Installation and Operation

INSTALLATION & PROGRAMMING INSTRUCTIONS FOR T2110

1. INSTALLATION: MECHANICAL AND ELECTRICAL

1.1 MECHANICAL

The T2110 is mounted in a panel or a cutout in a wall using 6, #10 flat head or pan head screws. Drawing SD0504-2 shows the center to center mounting dimensions and the dimensions of the rear case to allow you to set up proper clearances. The front panel of the unit itself may be used as a hole locating template. All connections to the T2110 are at the bottom of the rear case. When mounting in your installation, be sure to provide enough room for wire and cable entry. For surface mounting, EMS can provide a stainless steel box with or without a hood.

1.2 ELECTRICAL

Connections

There are two required connections and two optional connections to the T2110. They are telephone, power and the Auxiliary Output contacts. Drawing SD0504-2 identifies these connections for units with the new style PC Board. Drawing SD9706-2 identifies these connections for units with the old style PC Board.

Telephone

The T2110 has an analog telephone interface and will operate on any phone line where a standard telephone will operate whether it is a central office connection or an analog PBX or keysytem connection. Even though it is a speakerphone, it draws no more energy from the phone line than a standard handset phone. This means that, if necessary, more than one T2110 can share a phone line. The telephone connection to the T2110 is through a standard RJ-11 modular jack as shown in drawing SD0504-2 or drawing SD9706-2 respectively. Using normal telephone wiring color coding, the T2110 is connected to the red and green wires in the modular cord.

Power

The T2110 may be powered from an isolated DC supply of 12 to 24 volts. The connection to the unit is through a three-prong male post connector. The center post is positive and the two outer posts are negative. The power may be provided either remotely or at the phone. EMS provides an isolated AC to DC converter with each unit. The input is 115 VAC and the isolated output is about 13 Volts DC. When powering the T2110 from a remote DC source, consideration must be made for the resistive line drop of the wire used. The T2110 will operate at 1000 feet using the supplied isolated AC to DC converter with #22 AWG solid copper wire and at 3000 feet using #18 AWG solid copper wire. For multiple phone installation where it is desirable to power the T2110s remotely, EMS can provide power supply assemblies.

Should the loss of input power occur, the T2110 contains a NiCad backup battery pack, which will maintain the phone in operation for at least four hours. The battery pack is normally trickle charged from the input power source. There is a slide switch (shown in drawing SD0504-2 and drawing SD9706-2), which must be off when the unit is not connected to its power source in order to prevent battery drain.

Auxiliary Outputs

The T2110 has two available auxiliary outputs, which can be activated in various ways by the phone itself or by the call receiving agent. The outputs are optically isolated, solid state, normally open contact closures which, when closed have a maximum DC resistance drop of 35 ohms at the maximum allowable current of 120 milliamps. The auxiliary outputs are available at the 6 pin male post connector indicated in either drawing SD0504-2 or SD9706-2. The outputs may be used for activating strobe relays, door latches, etc.

2.0 OPERATION

2.1 OVERVIEW

The T2110 is a microprocessor based programmable, full-duplex speakerphone with one button activation. With its factory/default settings, once numbers to be dialed are programmed, it addresses the majority of the installations encountered. The factory default settings allow for calls to be received from the T2110 and calls to be made to the T2110 without any special keystrokes or codes on the part of the calling or receiving party. These factory default settings may be changed. Additional features can be activated by calling the T2110 from any touch-tone phone, entering a password and then two or three digit **program codes** along with the information to be changed or entered.

2.2 OUTGOING CALLS

Emergency Calls

When someone presses its button, the T2110 goes off hook, turns on the red light, dials the first programmed number, and waits to see if it has made a connection. If not, it goes on to the second number (if there is one programmed), and does the same thing. If the second number fails and there is a third programmed number, the T2110 tries that. If the third fails and there is a fourth, the T2110 tries that. If all programmed numbers fail, the phone repeats the whole process until it has tried all programmed numbers three times. The T2110 is physically identical to the T2100 except that there is a second button on the front panel of the T2110. This button is labeled "INFO" and is normally used for non-emergency communications to pre-programmed numbers. Operation of the "INFO" button is identical to that of the "PUSH FOR HELP" button except that calls made via the second button can be over-ridden by pressing the "PUSH FOR HELP" button. The T2110 can also be programmed so that calls made via the "INFO" button also activate the Auxiliary Outputs.

If the T2110's default setting of **voice answer** (code 80) is set, it turns on the green light which starts to blink, and plays the recorded message zero, one, two, or three times after the receiving agent answers the call and speaks. Two-way conversation can immediately begin. No keypad entry is required from the agent.

If the T2110 has been programmed for **tone answer** (code 81), it begins playing the message as soon as it dials each number. The message repeats until the answering agent acknowledges the call with a DTMF tone, at which time the green LED lights and the message replays zero, one, two, or three times. It is essential in **tone answer** that the receiving agent responds with a 1, 2 or 3 keypad entry to allow two-way conversation. If no entry is detected, the T2110 will continue to play the messages until it goes on to dial the next emergency number as described above.

Whether in **voice answer** or **tone answer mode**, once the connection is established, the agent can enter the following DTMF tones from the telephone keypad:

- 1: Will set the call timer to 2 minutes.
- 2: Will set the call timer to 5 minutes.
- 3: Will set the call timer to 10 minutes.
- 6: Will activate Auxiliary Output 2 if it has been programmed for manual operation.
- 7: Will transmit the phone's computer identifier.
- 8: Decreases speaker volume (in steps of 1) Speaker Range 1-20, Factory Default = 10
- 9: Increases speaker volume (in steps of 1)
- *8: Decreases Microphone volume (in steps of 1) Microphone Range 1-20, Factory Default = 10
- *9: Increases Microphone volume (in steps of 1)
- 0: Will repeat the voice message.
- #: Will hang up.

Note: Commands "8", "9", "*8", and "*9" are only active on T2100 series units with the new style PC board.

Once the connection is established, the T2110 will hang up if any of five things happens:

1. The answering party hangs up and the telephone system is capable of transmitting a momentary drop in line current (CPC, positive disconnect), which the T2110 senses.
2. The T2110 detects a dial tone or a reorder (fast busy) signal. Many telephone networks that do not signal with a momentary drop in line current will signal with dial tone or reorder instead.

3. The answering party transmits a “#” DTMF tone.
4. The call timer expires. This timer is programmable from 1 to 99 minutes. The “1”, “2”, and “3” DTMF tones, described above, reset this timer. Before the timer expires, the phone emits a warbling sound as a warning and gives the agent time to reset the timer.
5. The optional silence timer expires. This timer can be set from 10 to 99 seconds, or it can be disabled. It is intended for use with telephone networks that do not signal with a drop in line current and do not generate reorder. The silence timer is usually not needed.

Backup Battery Warning Calls (Program Code 55)

If the T2110's source of power is disconnected and it has been relying on its battery power for fifteen minutes it can place a warning call. The phone goes off hook, dials the programmed battery number (usually a maintenance facility), waits for an answer, and then emits six short beeps. The answering party can interrogate the T2110 (to locate the phone in question) by entering a DTMF “0”, which causes the phone to play its voice message (or messages) and/or by entering a DTMF “7”, which causes the phone to emit its identifier (normally used for computer-assisted operations). If the answering party does nothing for five seconds, the phone repeats the six-beep sequence. If the answering party does nothing for three of these six-beep/five-second attempts, the phone hangs up.

2.3 INCOMING CALLS

Incoming calls to the T2110 may have a number of purposes. You may be calling the T2110 to talk to someone at that end (“converse mode”), to listen silently to what’s going on at the T2110’s location (“silent monitor mode”), or to program the T2110 (“program mode”). You will need to know the telephone number to which the T2110 is connected. Dial that number as you would any other number. If you are off site from the T2110 and not within its area code, the area code and possibly by a 1 will be required.

When the T2110 answers an incoming call, it emits a short beep to let you know that it has answered. It then waits two seconds for you to do nothing or to select one of the modes with your keypad.

Converse Mode “Ring Thru”:

If the factory/default (Code 70) of Ring Thru is set, after the two seconds the T2110 emits a single ring through its speaker and then behaves just as it does after a connection has been established in an outgoing call. Full duplex conversations with anyone at the phone can proceed. The T2110 will hang up in response to any of the conditions that terminate an outgoing call.

Converse Mode “Hang up”:

If the T2110 has been programmed for Hang Up (Code 71) you must press “1”, followed by a call in password, followed by “#”. If you have set the call in password to “123”, for example, you would enter “1123#”. If the call-in password is blank, you would simply enter “1#”. Full duplex conversation can then proceed. The T2110 will hang up in response to any of the conditions that terminate an outgoing call.

Silent Monitor mode:

Press “4”, followed by the call-in password and “#”. The T2110 beeps 3 times (over the line, not through the speaker) to let you know it has entered the mode. The speaker is disabled and there is no ring at the T2110. If the T2110 is programmed for a silence timeout, it is ignored. Pressing the “5” keypad key will activate the speaker in this mode. The T2110 will hang up in response to any of the conditions that terminate an outgoing call.

Programming mode:

Press “2”, followed by the programming password and “#”. The T2110 emits 3 beeps to acknowledge you are in the programming mode. It will wait 5 seconds for a programming code to be entered. After each successful entry it will beep three times and wait for the next code to be entered. An unsuccessful entry will result in a raucous buzz and the phone will wait for the next program code. Three unsuccessful entries will terminate the call. Pressing the # key or simply hanging up will also end the call.

Converse “Ring Thru” vs. “Hang Up”

Your choice for the “converse setting” is likely to depend upon whether the phone can be dialed from outside. If you are concerned about calls being made by unauthorized persons, you can limit the phone’s accessibility by selecting the “hang up” option. You will still be able to enter silent monitor or converse modes using explicit mode selection. A prank caller who doesn’t know the call in password will not be able to get into the

T2110. On the other hand, if unauthorized access is not a concern, you may want to leave the setting at “Ring Thru”, since in true emergency situations someone (fireman, EMT etc.) untrained in the phone codes may have the need to call into the T2110.

3.0 PROGRAMMING

3.1 HOW TO PROGRAM THE PHONE

Programming is done by calling the T2110 from any touch tone phone and pressing the appropriate keys on your telephone keypad. When the T2110 answers your call, it will emit a beep. To enter the programming mode, press **2#** on the keypad within 2 seconds of the beep. Programming is done by entering a **program code** followed by a **program item** followed by a **#** when required. Program items are any numbers or recorded words required by the T2110 to perform a function. (Some program codes do not require a program item and #). A list of all the program codes is shown in section 3.6.

After you press **2#**, the T2110 beeps three times to let you know it has entered the programming mode, and then waits up to 5 seconds for program code entries. After each *successful* program code entry, the T2110 beeps three times and waits 5 seconds for another program code entry. After each *unsuccessful* code entry, the T2110 emits a raucous buzz and waits for the next entry. The call will be terminated if any of the following occurs:

1. You hang up.
2. You press “#” when the T2110 is waiting for the beginning of an entry. Some programming entries are terminated with “#”, and a “#” at the end of such an entry will not hang the phone up.
3. If, for three times in a row you fail to begin an entry within five seconds and hear the raucous buzz.
4. If, for three times in a row you make an incorrect entry and hear the raucous buzz.

The general programming procedure is:

1. Call the T2110.
2. Wait for it to answer and acknowledge with a beep.
3. Enter “2 programming password #”. If there is no programming password, enter only “2#”. (The programming password is an optional feature designed to prevent programming by unauthorized callers).
4. Listen for three beeps.
5. Enter a *program code* followed by a *program item* if the code requires one. Wait for either three beeps, which tells you that your entry has been accepted, or a raucous buzz, which tells you that your entry has been rejected. To enter additional program codes, repeat steps 5 as many times as needed. Hang up.

3.2 PROGRAM CODE FORMATS

Each entry begins with a two or three digit program code. Each Program Code is described in section 3.6. The simplest entries consist entirely of the two-digit program code. Examples include the three voice message options (31 for single message, 32 for instruction setting, and 33 for “heard by both” setting). By simply entering the program code the feature is selected, or in some cases disabled. Other entries require the two or three digit program code to be followed by a string of digits, and by a pound sign (“#”).

For example, to set the first emergency number to 1 (800) 555-1234, you would enter the following: 511 1 800 555 1234 #. (Spaces are only shown here for clarity). This format is also used for entries that include numerical values. Another example is the overall call timeout (code 63). To set it to 60 minutes, you would enter 6360 #.

3.3 RECORDING VOICE MESSAGES

Enter the program code (10 or 11), wait for the beep, and speak (it’s just like leaving a message on an answering machine). You can shorten the message by pressing the # sign key after you finish your sentence. Suppose, for example, that the T2110 is set for a single 18-second message. If you wanted to record the word “Help!” without a following 17.5 seconds of silence, you would do the following:

Enter 10.

Wait for the beep.

Say “Help!”

Enter “1”.

The “1” is optional. If you leave it off, the phone will record for the full 9 or 18 seconds.

After the message is recorded, the T2110 plays your new message back for you and gives you 3 beeps.

3.4 EXAMPLE (PROGRAMMING)

For many installations, it will be sufficient to program a single voice message and one or two numbers for the T2110 to call. For example, if you desire to have the T2110 call the single number 555-1234 and play the message "Help is needed in parking garage levels 2", the programming required is the following:

1. Call the T2110.
2. Within 2 seconds of the beep, begin the following sequence on your keypad:
 - 2#
 - 10 "Help is needed in parking garage A level 2" - 1 message replays.
 - 72 <1> #: (Set number of message repetitions)
 - 5115551234# (Programs "PUSH FOR HELP" button)
 - 5215551235# (Programs "INFO" button)
 - # to exit programming.
3. Hang up.

The T2110 will respond with three beeps after a # sign or a program code that does not require a program item. It will respond with one beep after it first answers and also after the program codes for recording voice messages (10 and 11). If we include the T2110 response in the above example, the steps are as follows (T2110 response is in **bold**):

Dial T2100 1 beep, 2# 3 beeps, 10 1 beep "Help is needed..." 1 (message replays) 3 beeps, 721# 3 beeps, 5115551234# 3 beeps, 5215551235# 3 beeps, # Hang up

The T2110 is now programmed to dial a single number and play one voice message.

3.5 ADDITIONAL PROGRAMMING FUNCTIONS

The factory/default settings will probably be sufficient for most installations. This means that in most cases the only programming you will be required to do is to record a voice message and to tell the T2110 what number(s) to call when the "Push for Help" button is pressed. However, the T2110 has extensive capabilities that allow you to customize the phone to specific installation conditions.

The next section describes all of the program codes that can be programmed into the T2110. Program Codes either activate or deactivate a feature, or allow entry of a program item. Program Items are the numbers or messages to be programmed and are always followed by the # key to indicate completion. The following index of Program Codes indicates with angle brackets (<>) when a Program Item is required.

3.6 INDEX OF PROGRAM CODES

10: Record first voice message.

The T2110 can store up to eighteen seconds of speech, which can be treated as a single long message or two short ones (See commands 31 to 34, below). If the T2110 is programmed for either of the two-message modes (codes 32 and 34), each of their durations is limited to nine seconds. The process of recording a voice message is very much like leaving a message on an answering machine: You speak after a beep. The difference is that you can set the length of the message by entering "1" after you have spoken. If you don't do this, the phone will record for the full nine or eighteen seconds. After you enter the 1, the new message will replay for your review.

11: Record second voice message

This code will record a message of up to nine seconds if you have first programmed one of the two-message settings (codes 32 and 34). If the single-message setting has been selected (default), you will hear a raucous buzz when you enter the code "11".

19: Transmit firmware name and version.

The name and version number of the firmware are encoded as DTMF digits and transmitted. For example, version 1.0 of the T2110 firmware would transmit "2100*1*0". This code is normally used for computer installations.

20: Play back the first voice message.

This code allows you to review the voice message after programming to verify the message, just as you would when verifying an outgoing message on an answering machine. You must be in the programming mode to enter this code.

21: Play back the second voice message.

Allows the second voice message to be verified. However, if the single-message setting has been selected, you will hear a raucous buzz indicating no message is available for replay.

30: Select single message. (heard by agent only)

The entire voice message will be used to store a single message of up to eighteen seconds in length.

31: Select single message. (heard by both caller and agent) (Factory/Default setting)

The entire voice memory will be used to store a single message of up to eighteen seconds in length.

32: Select two messages (2nd message heard by agent only)

The voice memory is used to store two nine-second messages. They alternate during a button-activated call, with the first message being played to the agent and over the T2110 speaker, and the second message being played only to the agent.

34: Select two messages (heard by both caller and agent)

The voice memory is used to store two nine-second messages. They alternate during a button-activated call, with both messages being played to the agent and over the T2110 speaker. This option is useful if messages in two languages are required.

35: Turn on computer identifier (ANI) when an emergency call is answered**36: Turn off computer identifier (ANI) when an emergency call is answered****38: Enable voice messages on calls to all emergency numbers dialed (Factory/Default Setting).****39: Disable voice messages on calls to the first emergency number.**

Voice messages are not played if an emergency call is answered by the first emergency number.

This may be used when the first call answering location has a visual display of incoming calls, making a voice message unnecessary.

40: Set dial mode to DTMF. (Factory/Default setting)

DTMF means "Dual Tone Multi-Frequency", or tone dialing.

41: Set dial mode to pulse

This is the old-fashioned click-click-click of rotary phones.

42<digit> #: Set ring count (Factory/Default setting is 1)

This optional feature causes the T2110 to wait for the programmed number of rings before answering an incoming call. It is normally used when the T2110 shares a line with another non-emergency telephone that may be answered by a person. If the digit is 1, the T2110 will answer on the first ring. If it is 2, the T2110 will answer on the second, and so on up to ten. If the digit is zero or omitted, the T2110 will answer on the first ring.

43xx: Set ring time (Factory/Default setting is 30)

This is the adjustable time, in seconds, that the phone waits listening for an answer. The range is from 0 to 60 seconds, which is measured from the start of the call. However, it always listens to the first three rings (approximately 18 seconds) so the range is from approximately 18 seconds to 60 seconds.

44: Enable Auxiliary Output 1 on outgoing calls (Factory/Default setting)

This program code sets the phone so that Aux Out 1 closes when the phone is activated by pressing the "Push for Help" button. The Aux Out 1 remains closed until the call is terminated.

45: Disable Auxiliary Output 1 on outgoing calls

This program code sets the phone so that Aux Out 1 does not close when the phone is activated by pressing the “Push for Help” button. In this mode, the Aux Out 1 closure can be activated by pressing the 4 key at the receiving agent end for both incoming and outgoing calls. The AUX Out 1 contact will then remain closed until the call is terminated.

- 4: until the end of the call
- *1 for 10 minutes
- *2 for 20 minutes
- *3 for 30 minutes

46: Enable Aux Out 2 to echo Aux Out 1

This program code sets the phone so that Aux Out 2 closes and opens under exactly the same stimulus conditions as Aux Out 1.

47 <time> #: Set Aux Out 2 timer (Factory/Default setting is 0)

This program code allows Aux Out 2 to operate independently from Aux Out 1 and to be closed for a programmed period of time when the 6 key is pressed at the receiving end. The programmable closure time is from 1 to 9999 seconds and Aux Out 2 remains closed for the programmed time even after the call is terminated. If xxxx is programmed to 0, Aux Out 2 closes and remains on until the call is terminated.

48: Set Aux Out 2 to momentary operation

This program code sets the phone so that Aux Out 2 closes only during the time that the 6 key at the receiving end is pressed.

511 <phone number> #: Load first emergency number

This is the first number dialed when the “Push for Help” button is pressed. It can have from zero to twenty digits, including “*”, which tells the T2110 to insert a two second pause. This is sometimes needed after dialing an access code for an outside line. For ringdown systems this program item should be left empty. When the button is activated, the T2110 will go off hook but not dial.

512 < phone number> #: Load second emergency number (Factory setting is blank)

This is the optional second number dialed by the button. It can have from zero to twenty digits, including “*”, which tells the phone to insert a two second pause. This is sometimes needed after dialing an access code for an outside line. Leaving this program item empty disables the second number feature.

513 < phone number> #: Load third emergency number (Factory setting is blank)

This is the optional third number dialed by the button. It can have from zero to twenty digits, including “*”, which tells the phone to insert a two second pause. This is sometimes needed after dialing an access code for an outside line. Leaving this program item empty disables the third number.

514 < phone number> #: Load fourth emergency number (Factory setting is blank)

This is the optional fourth number dialed by the button. It can have from zero to twenty digits, including “*”, which tells the phone to insert a two second pause. This is sometimes needed after dialing an access code for an outside line. Leaving this program item empty disables the fourth number.

521 <phone number> #: Load first “INFO” number

This is the first number dialed when the “INFO” button is pressed. It can have from zero to twenty digits, including “*”, which tells the T2110 to insert a two second pause. This is sometimes needed after dialing an access code for an outside line. For ring down systems this program item should be left empty. When the button is activated, the T2110 will go off hook but not dial.

522 < phone number> #: Load second “INFO” number

This is the optional second number dialed by the button. It can have from zero to twenty digits, including “*”, which tells the phone to insert a two second pause. Leaving this program item empty disables the second number feature.

523 < phone number> #: Load third “INFO” number

This is the optional third number dialed by the button. It can have from zero to twenty digits, including “*”, which tells the phone to insert a two second pause. Leaving this program item empty disables the third number.

524 < phone number> #: Load fourth “INFO” number

This is the optional fourth number dialed by the button. It can have from zero to twenty digits, including “*”, which tells the phone to insert a two second pause. Leaving this program item empty disables the fourth number.

55 < phone number> #: Load backup battery warning number (Factory setting is blank)

If the phone is equipped with a battery, you may program a number for the T2110 to call automatically after 15 minutes of battery operation. Leaving this program item empty will disable this feature.

56 < number> #: Load computer identifier (ANI) (Factory setting is blank)

This number, up to twenty digits in length, is sent out in response to a “7” entered by the receiving agent during a call. It is normally used when the T2110 is connected to a computer for remote monitoring.

57 < number> #: Load programming password (Factory setting is blank)

The password can have from zero to twenty digits. Leaving this program item empty is legal and disables password protection, allowing you to get into the programming mode by entering only a “2#”.

58 <number> #: Load monitor password (Factory/Default setting is blank)

The password can have from zero to twenty digits. Leaving this program item empty is legal and disables password protection, allowing you to get into the converse or silent monitor mode by entering only a “1#” or “4#” respectively.

63 <number> #: Set maximum conversation time (Factory/Default setting is 10 minutes)

The number you program sets the time in minutes, (from 1 to 99) that a conversation can last between the caller and the receiving agent before an additional keypad entry by the agent must take place.

64 <number> #: Set silence timeout (Factory/Default setting is 0)

This feature is normally not needed and can be disabled by programming a “0”. If a silence timeout is desired, it may range from 10 to 99 seconds. A number in the range of 1 to 6 actually means 7, since 7 seconds is the minimum detectable silence.

65 <number> #: Set dial tone hangup time (Factory/Default setting is 0)

This option is used with telephone switches that do not generate CPC at the end of a call but that revert to dial tone instead. If it is set, the phone will terminate a call after xx seconds of continuous sound. The range is 5 to 99 seconds. Setting the number to 0 disables the feature. This option should be used carefully (i.e., set to a long interval), since it responds to continuous sound, regardless of pitch or any other characteristic.

66<number>#: Set fast busy hangup time (Factory/Default setting is 0)

This option is used with telephone switches that do not generate CPC at the end of a call but that revert to fast busy instead. If it is set, the phone will terminate a call after XX seconds of repetitive fast busy. The range is 7 to 99 seconds. Setting the number to 0 disables the feature.

70: Set Converse mode for incoming calls to the T2110 to “Ring Thru” (Factory/Default setting)

With this setting, the T2110 will automatically enter two way conversation mode if no keystrokes are entered after it has answered an incoming call. Full Duplex conversation can then take place.

71: Set answering mode for incoming calls to “hang up”

With this setting, the T2110 will hang up if no keystrokes are entered after it has answered an incoming call.

72 <number> #: Set number of message repetitions (Factory/Default setting is 0)

This is the number of times the message is played after the agent has answered. It can vary from zero to three. Setting it to zero stops the phone from playing voice messages automatically, but it doesn’t stop the phone from playing voice messages in response to a DTMF keypad entry of “0” by the agent.

73: Enable Aux Out 1 and Aux Out 2 on non-emergency calls.

This program code allows Aux Out 1 and Aux Out 2 to be activated on calls made by pressing a non-emergency button exactly as they are activated by pressing the “PUSH FOR HELP” button.

74: Disable Aux Out 1 and Aux Out 2 on non-emergency calls. (Factory/Default setting)

This program code only allows Aux Out 1 and Aux Out 2 to be activated on calls made by pressing the “PUSH FOR HELP” button.

80: Select voice answer (enables call progress monitoring) (Factory/Default setting)

Call progress monitoring is the process by which the phone detects speech, ringing, busy signals, etc., and uses these to know when to abandon unsuccessful call attempts and when to play the voice message. This is an important feature that eliminates training an agent on keypad entry codes.

81: Select tone answer (disables call progress monitoring)

This mode can be used if call progress monitoring doesn't work properly because of noisy lines or nonstandard exchanges. In this mode:

1. Busy signals and reorder tones are not recognized. Instead, the phone times out unsuccessful calls after thirty seconds.
2. The voice messages begin playing as soon as the button is pushed.
3. The agent must press a tone key (a 1, 2 or 3 on the keypad) to let the phone know that the call has been answered. After the keystroke, the voice message is played (in its entirety) normally twice, depending on the program code (72), and two-way conversation is enabled.

82: Normal CPC operation

All CPC pulses are interpreted as ending a call.

83: Enable CPC rejection mode

The first CPC pulse to occur before a call is answered is ignored.

84: Disable CPC detection altogether

This mode is normally only used when it is necessary to troubleshoot an installation.

89xx: Ringback tone silence time (Factory/Default setting is 7 seconds)

This may be set from 7 to 99 seconds. Any number below seven is set to seven. This allows for adjustment of the time the phone listens for a ringback tone to verify that a valid call has been placed. This time is sometimes very long in cellular applications.

90: Set Default settings

The T2110 is returned to its default configuration (See "Default settings", below). The voice messages and stored telephone numbers are unaffected.

3.7 DEFAULT SETTINGS

The T2110 is shipped with the following default settings which will be sufficient for most installations:

- | | |
|--------|---|
| 31 | The voice playback is set for a single message heard by caller and agent. |
| 36 | The automatic ANI on answer is disabled |
| 38 | If option 72 is set for a number other than zero, then the voice message will be played after any emergency call is answered. |
| 40 | The dial mode is set to tone, rather than pulse, dialing. |
| 42(1) | The ring count is set to answer on the first ring. |
| 43(30) | The ring time for outgoing calls is set to 30 seconds. |
| 44 | Aux Out 1 is automatic with "Push for Help" button |
| 47(0) | Aux Out 2 is activated to end of call with keypad 6 |
| 58 | Call In password is blank. |
| 63(10) | The maximum conversation time is set to ten minutes. |
| 64(0) | The silence timeout is disabled. |
| 65(0) | Dial tone hang up detection is disabled |
| 66(0) | Fast Busy Detection is Disabled |
| 70 | The Converse mode for incoming calls is set to "Ring Thru". |
| 72(0) | The number of repetitions of the voice message after connection is set to 0. |
| 74 | Disable Aux Out 1 and Aux Out 2 on non-emergency calls. |
| 80 | "Voice Answer" is set. Enables call progress-monitoring capabilities. |
| 82 | Normal CPC detection is enabled |
| 89(7) | Maximum ringback tone silence time is set to seven seconds |

If you wish to return the T2110 to the default settings after you have programmed the phone, you can simply program a code 90. Previously recorded voice messages and programmed phone numbers will not be affected.

4.0 Troubleshooting Guide

Always visually check the phone for loose or shorted wires, physically damaged or missing components. The phone will not work on a Digital phone line. It will **only** work on **an Analog** phone line or an Analog port from a digital phone system.

Problem: Phone would not turn 'ON'

Possible Cause:

- Check Power supply voltage at the J2 three pin connector. (Normally 6-24VDC)
- Check polarity on the J2 power connector. The 2 outer pins are negative and the center pin is positive.
- Check phone line connection. (Phone line plugs into the J1 connector)
- Check phone line voltage (Normal C.O. line 48-52VDC or 20-35VDC – Internal systems)
- Check if unit is pulling down line voltage (You should read the same as the phone line voltage)
- Check voltage at controller
- On an OEM style phone Remove button connector and try shorting button connection at J10 pins.

Problem: Phone Dials Incorrect number

Possible Cause:

- Check number programmed into phone
- Plug a phone in the same line as your phone and call the same number you are trying to program to see if you can call out.
- Check to see if the phone is on a ring down line
- Check to see if another auto dialer is on the line and remove it
- Reprogram unit

Problem: No sound thru speaker

Possible Cause:

- Check speaker connection (Speaker plugs into the J3 connector)
- Try calling into unit and speaking to person.
- Make sure that the R12 Volume pot is adjusted properly.
- Call into the phone and program the default code "90" that will reset the speaker volume.

Problem: Noise on the line

Possible Cause:

- Measure AC voltage on line, should be zero
- Try a spare pair of wires thru phone cable.
- Check power supply at J2. It must be 6-24 Volts isolated DC power supply.

Problem: Phone dials out but has broken communication

FCC Notice:

This equipment complies with Part 15 and part 68 of the FCC Rules. Operation subject to the following two conditions: (1) This device may not cause harmful interference, and (2) This device must accept any interference received, including interference that may cause undesired operation. On this unit is a label that contains, among other information, the FCC registration number and ringer equivalence number (REN) for this equipment. If requested, this number must be provided to the telephone company.

The REN is used to determine the number of devices that may be connected to a telephone line. Excessive RENs on a telephone line may result in the devices not ringing in response to an incoming call. In most but not all areas, the sum of RENs should not exceed five (5.0). To be certain of the number of devices that may be connected to a line, as determined by the total RENs, contact the local telephone company. For products approved after July 23, 2001, the REN for this product is part of the product identifier that has the format US:AAAEQ##TXXXX. The digits represented by ## are the REN without a decimal point (e.g., 03 is a REN of 0.3). For earlier products, the REN is separately shown on the label.

If this equipment causes harm to the telephone network, the telephone company will notify you in advance that temporary discontinuance of service may be required. But if advance notice isn't practical, the telephone company will notify the customer as soon as possible. Also, you will be advised of your right to file a complaint with the FCC if you believe it is necessary.

The telephone company may make changes in its facilities, equipment, operations or procedures that could affect the operation of the equipment. If this happens the telephone company will provide advance notice in order for you to make necessary modifications to maintain uninterrupted service.

If trouble is experienced with this equipment, for repair or warranty information, please contact EMS 1-800-527-9156. If the equipment is causing harm to the telephone network, the telephone company may request that you disconnect the equipment until the problem is resolved.

Connection to party line service is subject to state tariffs. Contact the state public utility commission, public service commission or corporation commission for information.

**WHEN PROGRAMMING EMERGENCY NUMBERS AND
(OR) MAKING TEST CALLS TO EMERGENCY NUMBERS:**

- 1) Remain on the line and briefly explain to the dispatcher the reason for the call.
- 2) Perform such activities in the off-peak hours, such as early morning or late evenings.

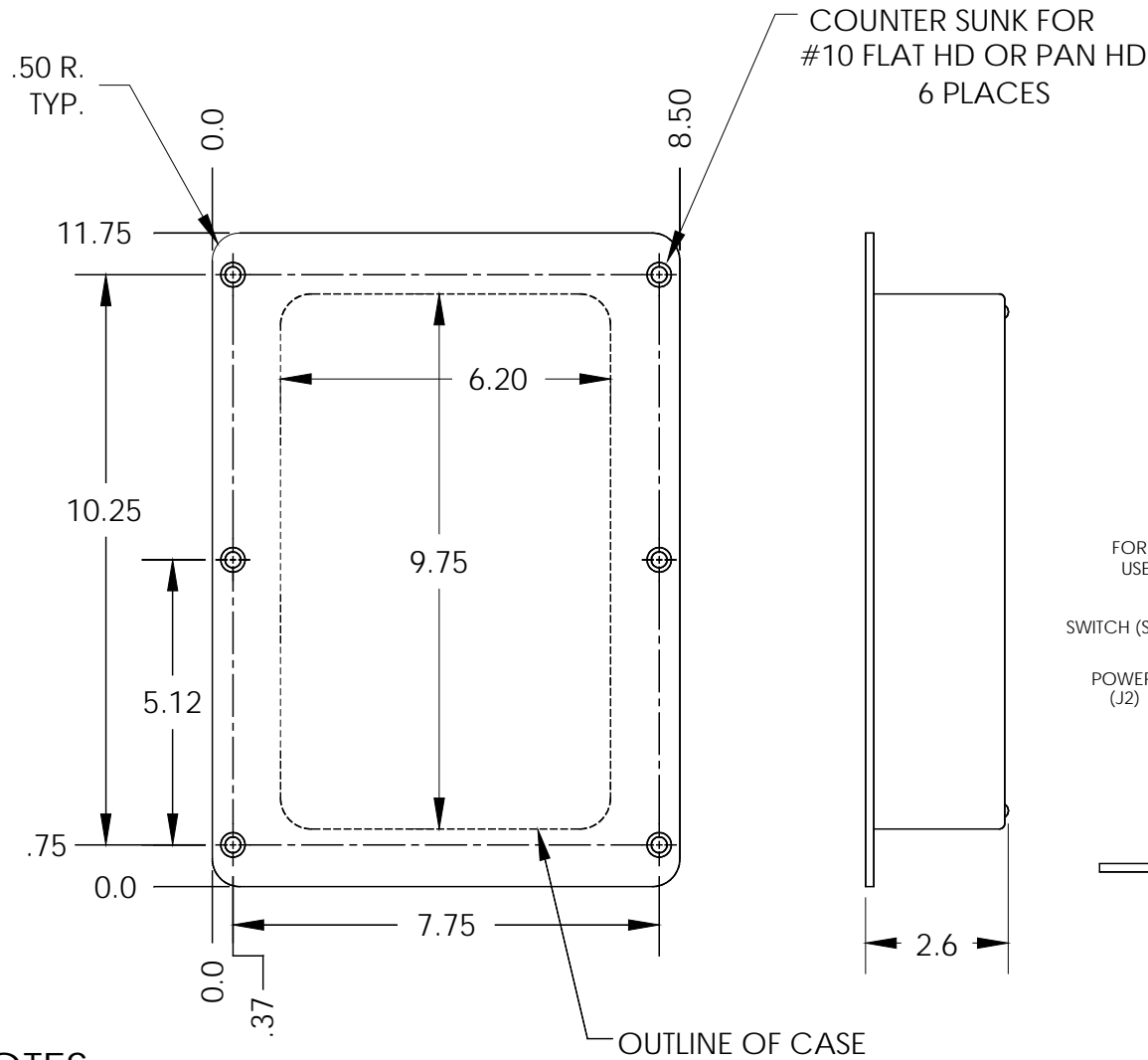

PIN	AUXILLIARY J11
1	AUX 1
2	AUX 1
3	AUX 2
4	AUX 2
5	NO CONNECTION
6	NO CONNECTION

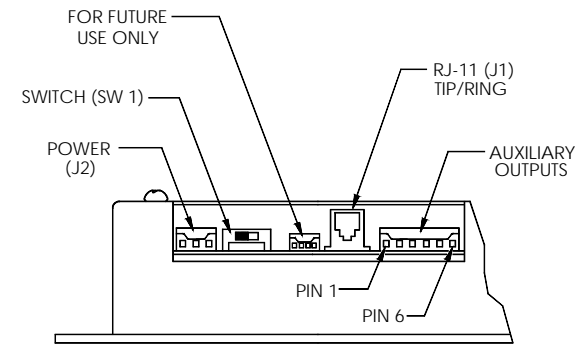

NOTES

1. FRONT PANEL: 304 SS, .100 THK.

MOUNTING & CONNECTION DIAGRAM FOR T2100 SERIES UNITS WITH NEW STYLE PCB

SD0504-2B



Janus Elevator Products/EMS

125 RICEFIELD LANE
HAUPPAUGE, N.Y., 11788
(631) 864-3699 FAX (631) 864-2631

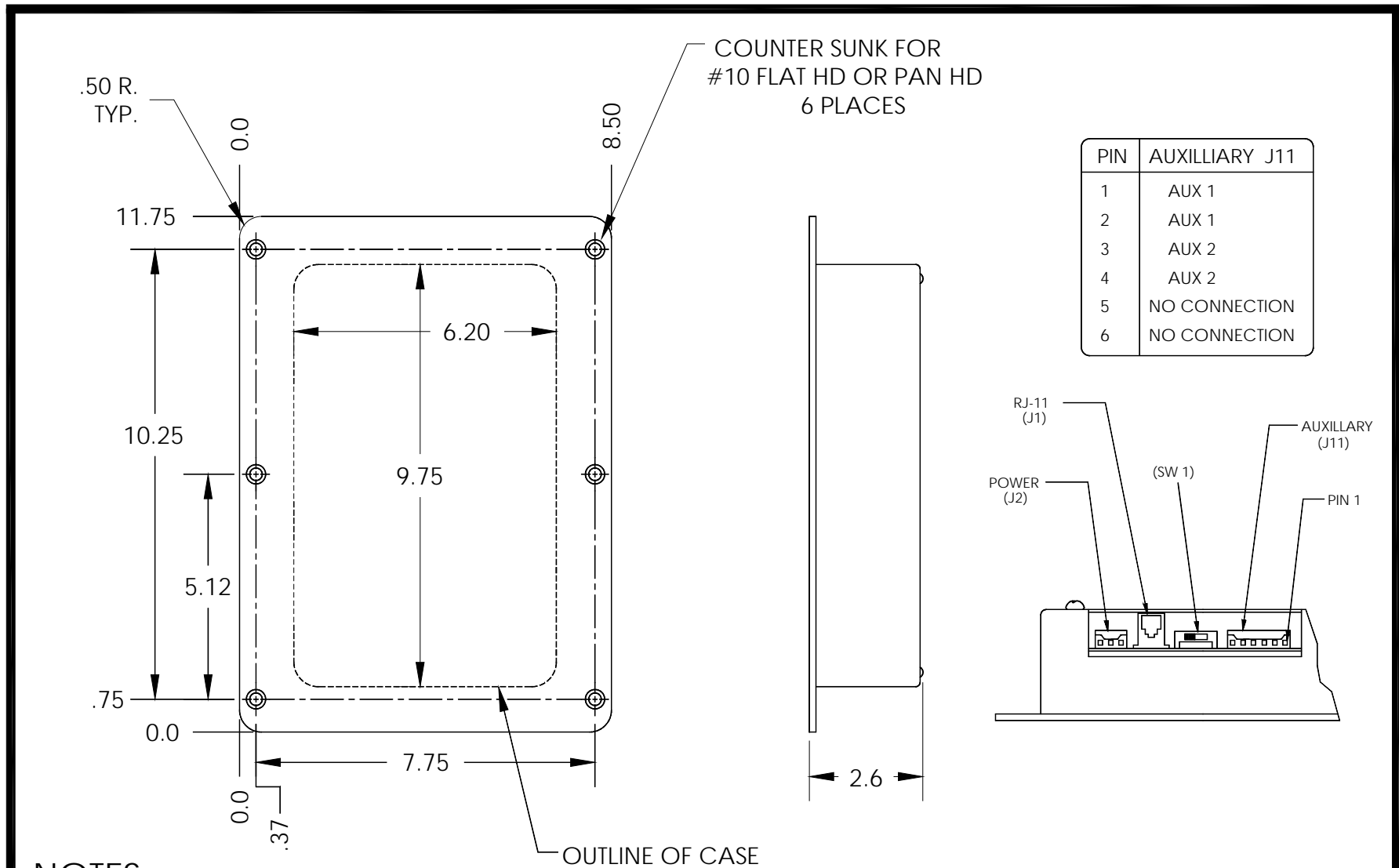

NOTES

1. FRONT PANEL: 304 SS, .100 THK.

SD9706-2B

MOUNTING & CONNECTION DIAGRAM FOR T2100 SERIES UNITS WITH OLD STYLE PCB



Janus Elevator Products/EMS

125 RICEFIELD LANE
HAUPPAUGE, N.Y., 11788
(631) 864-3699 FAX (631) 864-2631