

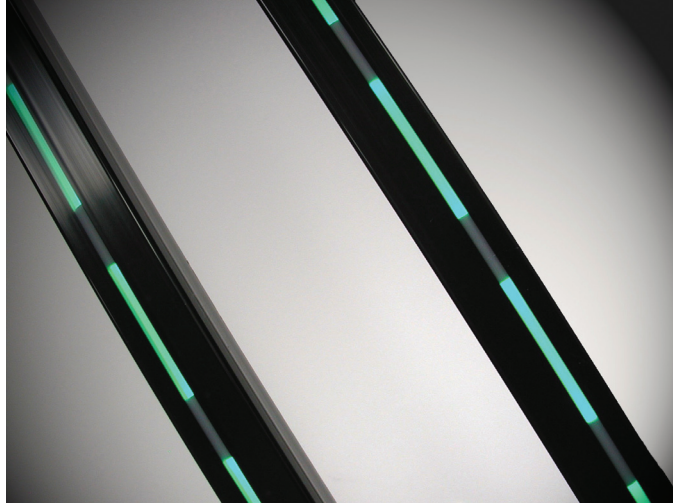

JANUS

# Panachrome 3D

Providing Passenger Safety that is Second to None



## Panachrome

*The Panachrome is the only light curtain that will illuminate green if the doors are opening, flash red as they start to close, and stay red as the doors are moving together.*



The Panachrome door edge system is the revolutionary new elevator safety detection system offering maximum passenger protection. The traditional infra-red light curtain is coupled with colored indicators that operate on door movement, or that can be manually triggered with door open/close circuit. The detectors will illuminate green if the doors are opening, flash red as they start to close, and stay red as the doors move together. The combined system is an effective solution for sites where extra caution is required on the elevator .

## Features & Benefits

- Complies with American Disability Act
- Coverage exceeds minimum requirements of 1" to 70.9"
- Colored red/green indication to highlight door movement
- Infra-red detection delivered as 154 beam light curtain
- 13 foot pluggable cable
- 18 foot range
- Choice of 3/8" and 1 5/8" profiles
- High resistance to water and dust
- Simplified installation
- Can be used on center-opening and side opening doors
- Superior **3D** protection
- Patent pending



Flashes red as doors  
start to close

## Specifications

- 154 Beams
- 120-240VAC Power Input, 18-25 VDC
- Door Operator Relay 240VAC, 24VDC at 5A
- 72.0" Level of Highest Beam
- 0.75" Level of Lowest Beam

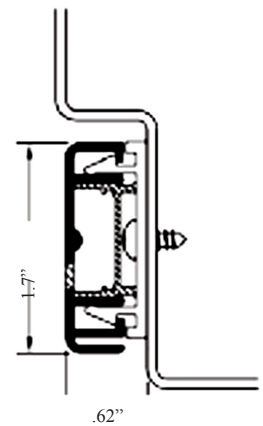
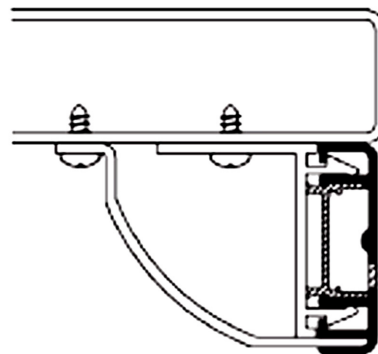
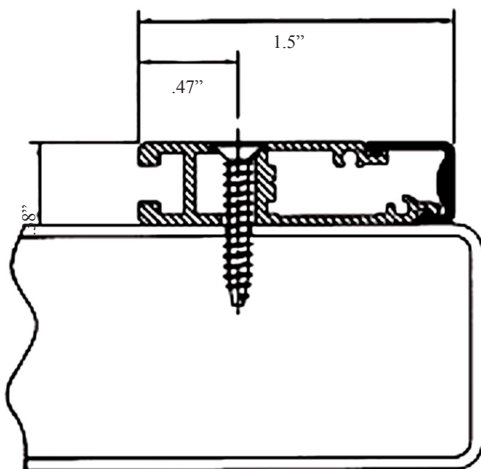
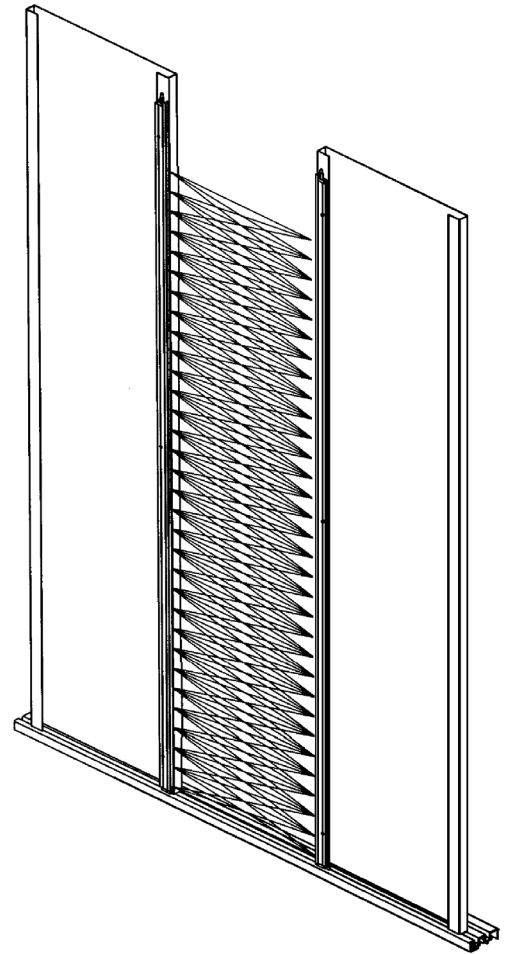

125 Ricefield Lane  
Hauppauge, NY 11788  
Phone: 631 864-3699 • 800 527-9156  
Website: [www.januselevator.com](http://www.januselevator.com)  
E-mail: [sales@januselevator.com](mailto:sales@januselevator.com)