



Providing Passenger Safety that is Second to None

PBX phone



PBX Elevator Phone

The New PBX elevator phone is your best choice for a unit to mount in your phone cabinet.

The PBX elevator phone is in a new improved format. Fully ADA compliant and made to fit into your phone cabinet. This phone has the reliability and features that you have come to expect from EMS products. Now providing new benefits and features.

Features & Benefits

- Phone line powered
- ADA compliant
- Phone line monitoring available
- On board Keypad
- Optional on board relay
- Mounts in a phone cabinet
- Built in four number dialer
- Extended voice chip capability
- Easy installation and programming
- Fully programmable voice chip
- Available in one or two LED version
- FCC Registered
- CSA Listed
- Two-year warranty
- Positive acknowledgement of alarm received
- Call can only be acknowledged by operator, is not fooled by answering machines or voice recordings
- Voice prompts reduce operator error

Janus Elevator Products Inc.



Specifications

- Size: 8.93" H x 4.90" W x 2.09" D
- Weight: 1/2 lbs.
- Power: Telephone line powered (48vdc to 50vdc typical)
- Optional AC adaptor: (9vdc@200mA)
- Loop current range: 10mA to 60mA (20mA typical)
- REN: 0.2B
- Dialing: DTMF (Dual Tone Multi Frequency)
- Frequency Response: 550Hz - 3400Hz, +/- 3db
- Operating Temperature Range: -40 to +85 degrees C
- Relative Humidity: Up to 95% (non-condensing)

ADA Compliant, superior performance

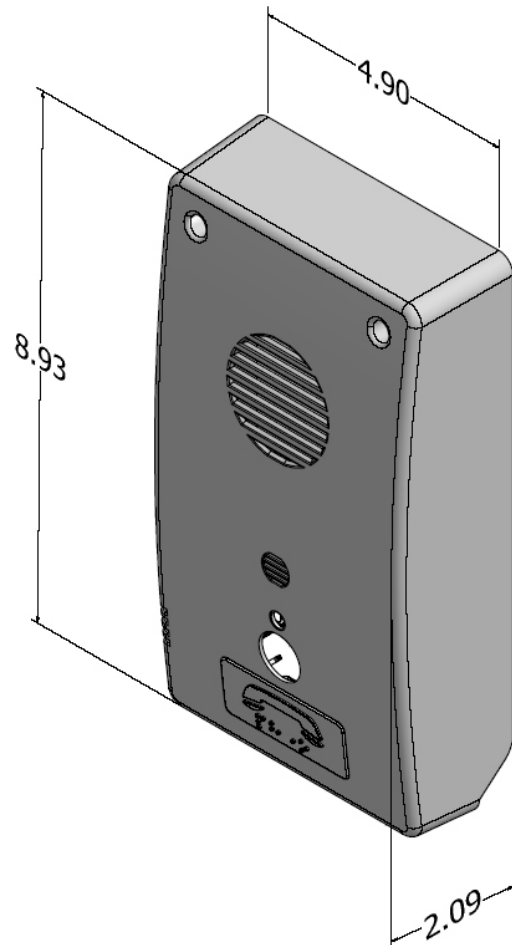
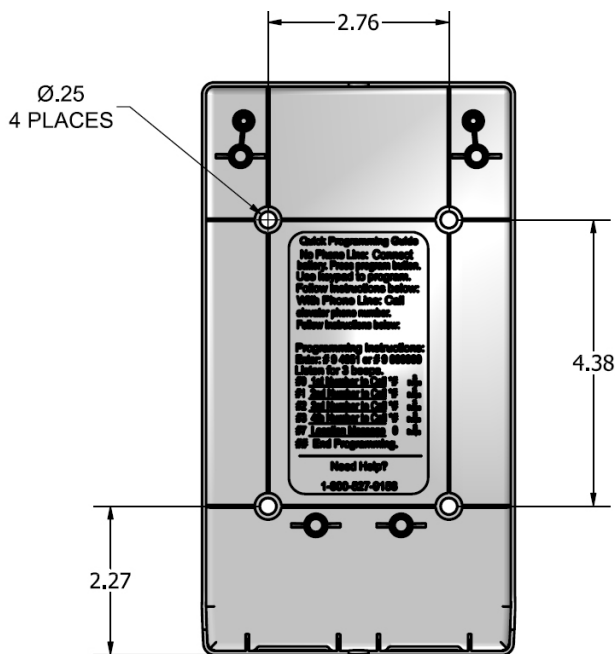

125 Ricefield Lane
Hauppauge, NY 11788
Phone: 631 864-3699 • 800 527-9156
Website: www.januselevator.com
E-mail: sales@januselevator.com

JANUS A HALMA COMPANY