

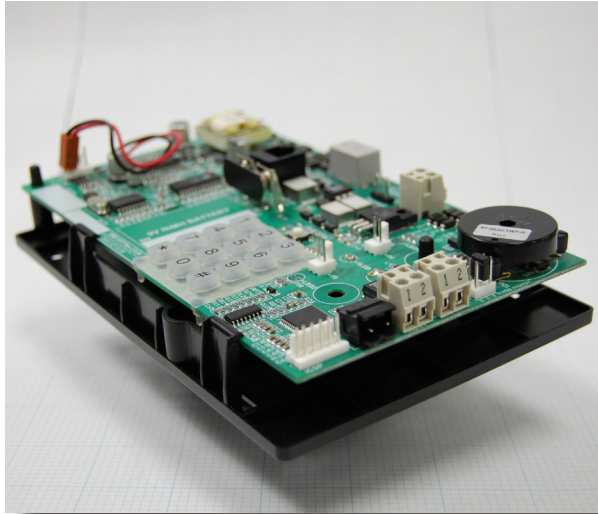

Providing Passenger Safety that is Second to None

PNB Phone



PNB Elevator Phone

The New PNB elevator phone is your best choice for a unit to mount behind the elevator car panel.

The PNB elevator phone is in a new improved format. This unit mounts behind the car operating panel. This phone has the reliability and features that you have come to expect from EMS products. Now providing new benefits and features.

Features & Benefits

- Phone line powered
- ADA compliant
- Phone line monitoring available
- On board Keypad
- Optional on board relay
- Mounts behind the COP
- Built in four number dialer
- Extended voice chip capability
- Easy installation and programming
- Fully programmable voice chip
- Available in one or two LED version
- Available in two piece format
- FCC Registered
- CSA Listed
- Two-year warranty
- Positive acknowledgement of alarm received
- Call can only be acknowledged by operator, is not fooled by answering machines or voice recordings
- Voice prompts reduce operator error

Specifications

- Size: 4.51" W x 7.02" H x 1.43" D
- Weight: 1/2 lbs.
- Power: Telephone line powered
(48vdc to 50vdc typical)
- Optional AC adaptor: (9vdc@200mA)
- Loop current range: 10mA to 60mA
(20mA typical)
- REN: 0.2B
- Dialing: DTMF (Dual Tone Multi Frequency)
- Frequency Response: 550Hz - 3400Hz, +/- 3db
- Operating Temperature Range: -40 to +85 degrees C
- Relative Humidity: Up to 95% (non-condensing)



Compact size, superior performance

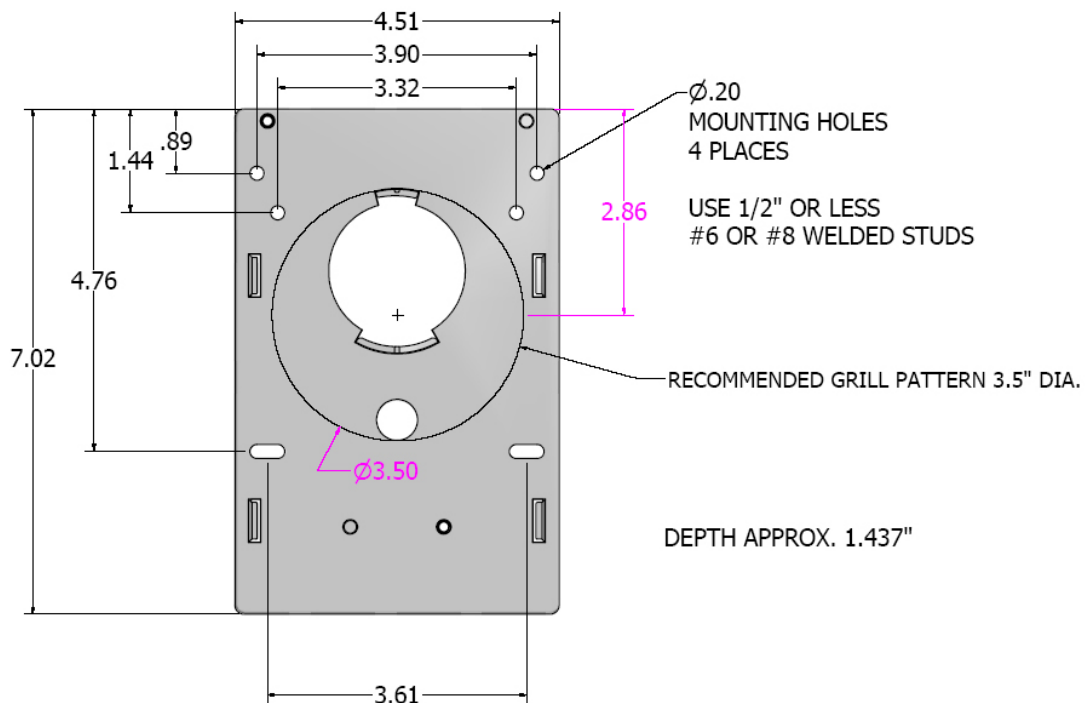

125 Ricefield Lane
Hauppauge, NY 11788
Phone: 631 864-3699 • 800 527-9156
Website: www.januselevator.com
E-mail: sales@januselevator.com